

SUMMIT[®]



GAS GRILL

Built-In LPG Gas Grill Installation Guide

Assembly - Pg. 7 • Tank Enclosure Installation - Pg. 26

460 - LPG

660 - LPG

#56861



YOU MUST READ THIS OWNERS GUIDE BEFORE OPERATING YOUR GAS BARBECUE.

⚠ DANGER

If you smell gas:

1. Shut off gas to the appliance.
2. Extinguish any open flames.
3. Open lid.
4. If odor continues, keep away from the appliance and immediately call your gas supplier or your fire department.

Leaking gas may cause a fire or explosion which can cause serious bodily injury or death, or damage to property.

⚠ WARNING:

1. Do not store spare LPG cylinder within 10 feet (3m) of this appliance.
2. Do not store or use petrol or other flammable liquids or vapors within 25 feet (8m) of this appliance.

⚠ WARNING: Follow all leak-check procedures carefully in this manual prior to barbecue operation. Do this even if the barbecue was dealer-assembled.

NOTICE TO INSTALLER: These instructions must be left with the owner and the owner should keep them for future use.

THIS GAS APPLIANCE IS DESIGNED FOR OUTDOOR USE ONLY.

⚠ WARNING: Do not try to light this appliance without reading the Ignition Instructions section of this manual.

BUILT-IN CUTOUT DIMENSIONS

“ISLAND” STRUCTURE CONFIGURATION OPTIONS

There are several configuration options for the grill and gas supply access of your Island structure.

The 3 common options (A, B, C) are illustrated in the “Island” Structure Configuration Options” table. ♦

“ISLAND” STRUCTURE CONFIGURATION OPTION

1	Summit® 4-burner/6-burner grill
2	Gas supply

LOCATING YOUR GRILL

When determining a suitable location for your Summit® gas grill installation, give attention to concerns such as exposure to wind, proximity to traffic paths, and keeping any gas supply lines as short as possible. Never locate the Summit® gas grill in a garage, breezeway, shed, under an unprotected overhang, or other enclosed area. Locate the grill and structure so there is enough room to safely evacuate the area in case of a fire.

CLEARANCE FROM SURFACES OR STRUCTURES

⚠ WARNING: Clearance from any surface or structure is 24" (610 mm) from the back and sides of the grill. Refer to “TYPICAL GAS SUPPLY INSTALLATION” before starting installation.

⚠ WARNING: The structure, “island”, countertops, and adjacent work areas for the built-in grill installation must be built from noncombustible materials only.

NOTE: If you have questions on what materials are considered noncombustible, contact your local building materials supplier or fire department. ♦

BUILT-IN STRUCTURE CUTOUT DIMENSIONS

All dimensions are to finished surfaces.

⚠ WARNING: All countertop finished surfaces must be constructed of a noncombustible material. ♦

CLEARANCES

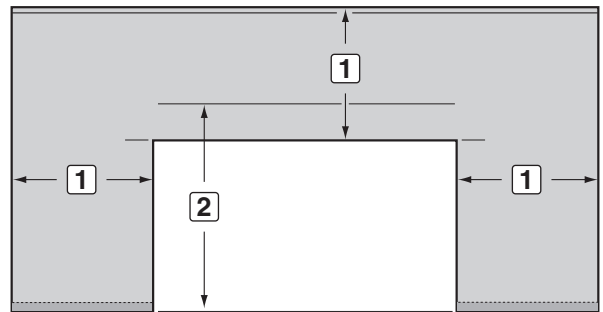

1	24" (610 mm) any surface
2	27" (686 mm) minimum for lid clearance

BUILT-IN CUTOUT GENERAL DIMENSIONS

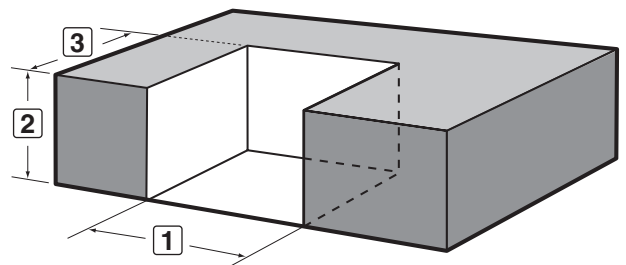

	460	660	TOLERANCES
1	34" (864 mm)	42" (1067 mm)	±1/4" (6 mm)
2	36" (914 mm)	36" (914 mm)	max
3	24 5/16" (618 mm)	24 5/16" (618 mm)	±1/4" (6 mm)

BUILT-IN CUTOUT DIMENSIONS

GENERAL CONSTRUCTION DETAILS

The Summit® Built-In unit should be on site before construction begins.

For ease of installation, the grill will be pushed on its casters into the built-in structure.

The installation of this grill requires a level floor pad surface (1) and countertop surface. The floor pad surface must be constructed from solid materials and must be level and smooth. Proper subgrade materials must be used under the floor pad to prevent materials from settling and heaving.

Rotisserie Outlet

If the supporting structure is going to have an electrical outlet for a rotisserie, it should be on the left side of the structure. ♦

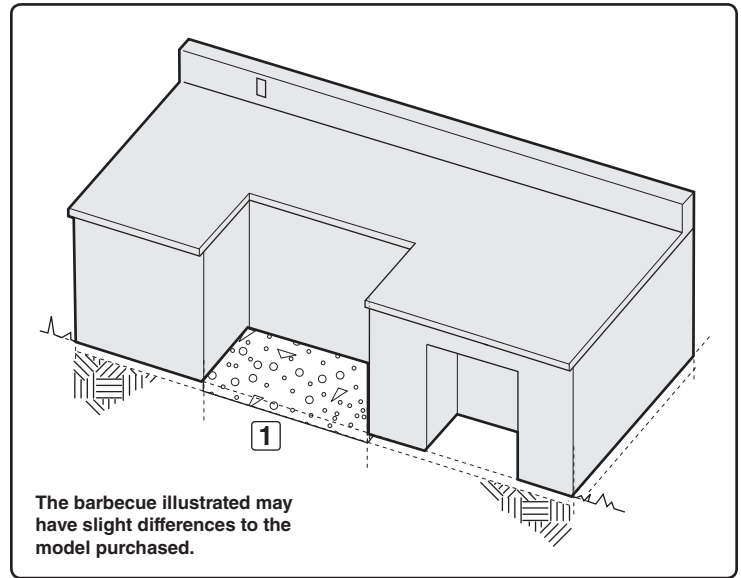

BUILT-IN CUTOUT DETAILED DIMENSIONS

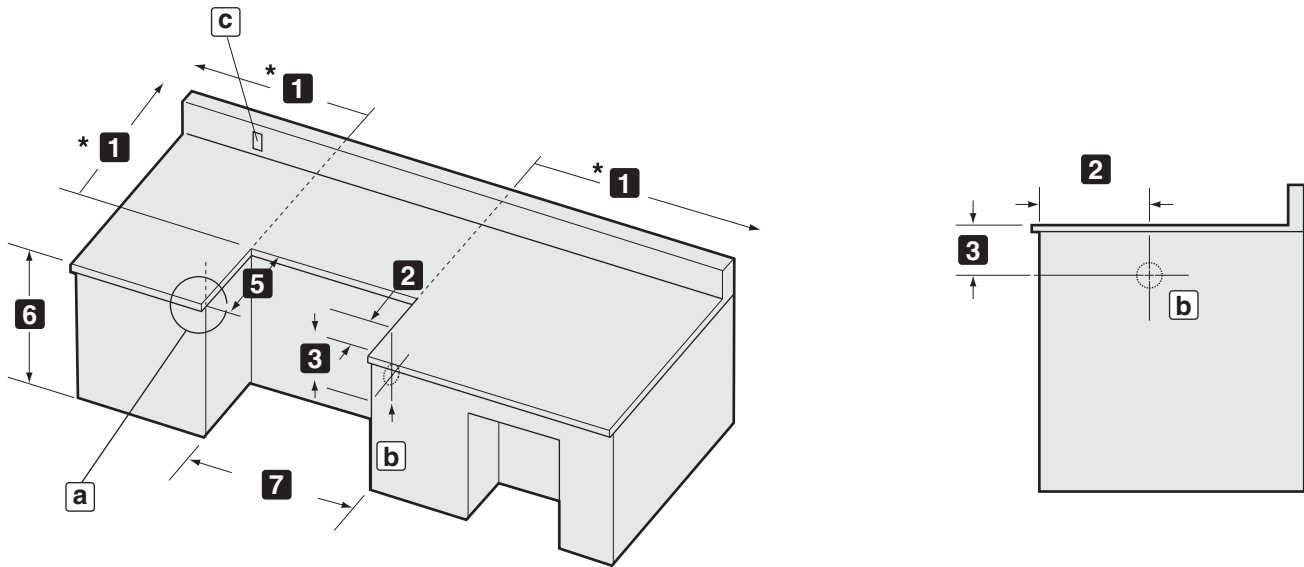

		460	660
DIMENSIONS	1	24" minimum* (610 mm)	24" minimum* (610 mm)
	2	16 1/2" (419 mm)	16 1/2" (419 mm)
	3	11 1/8" (283 mm)	11 1/8" (283 mm)
	4	10 1/2" (267 mm) minimum	10 1/2" (267 mm) minimum
	5	24 5/16" (618 mm)	24 5/16" (618 mm)
	6	36" (914 mm) maximum	36" (914 mm) maximum
	7	34" (864 mm) Built-In frame	42" (1067 mm) Built-In frame
	a	For a countertop treatment: recommended 3/4" (19 mm) overhang.	
	b	Gas inlet	
	c	Access for electric on left hand side	

BUILT-IN TANK ENCLOSURE PARTS LIST / ASSEMBLY

CONNECT GAS SUPPLY

A 58" (147.32 cm) corrugated gas line is connected to the manifold of the grill.

- A) The main corrugated line passes through the "Island Structure" cavity to the hose and regulator connection inside the tank enclosure (1).
- B) Uncap the flare fitting from the 90° Connection on the regulator hose located inside the tank enclosure (2).
- C) Connect the main corrugated hose to the 90° bulkhead fitting. Use the 1/2" (12.7 mm) flared gasket to ensure proper seal (3).

Note: 1/2" flared gaskets are included in the Summit® Built-In tank Enclosure Kit included with your grill. ♦

CONNECTION CHART

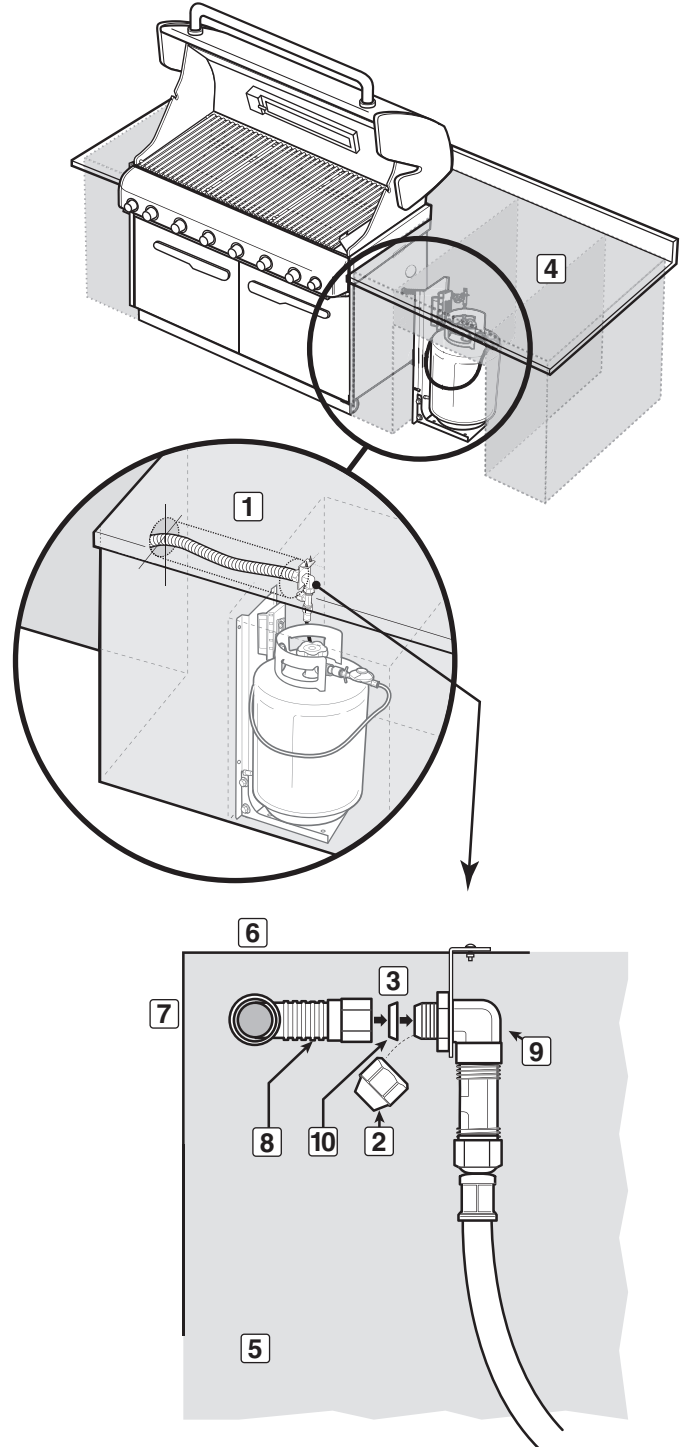

4	Typical tank cabinet or tank enclosure location
5	Side view
6	Top of box
7	Back of box
8	Corrugated gas line to manifold
9	90° fitting
10	1/2" (13 mm) flared gasket

BUILT-IN TANK ENCLOSURE ASSEMBLY VENTILATION

VENTILATION

⚠ WARNING: Ventilation holes must be provided in the structure at the top and bottom to provide ventilation in the event of a gas leak.

Ventilation holes can be located in a low visibility area and should be protected by screening material to prevent rodents and insects from entering the structure. Air holes will also help dry moisture.

Note: These drawings are only a reference.

- Cross ventilation must be incorporated in the supporting structure. We recommend a minimum of 100 square inches (254 square cm) of venting per side.
- Vents should be on two sides of the structure.
- The drawings are for reference only.
- Location of the vents should be from the center, outward.
- Locate the vents at both the bottom of the structure and at the top of the structure.
- The bottom vents should be as close to ground level as possible. Make sure the vent area is not blocked by interior supports of the structure.
- We recommend vents with screens.
- Access doors to the structure are not considered vents.
- Clean the vents periodically.

⚠ DANGER

Failure to follow recommended minimum venting instructions can cause gas to collect in the structure in the event of a gas leak. This may result in a fire or an explosion which can cause serious bodily injury or death, and damage to property. ♦

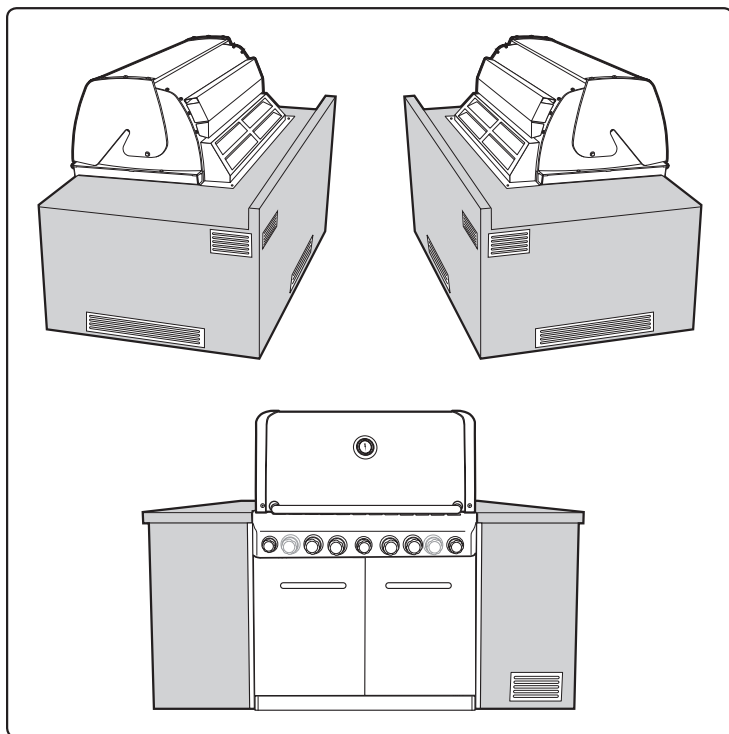

⚠ ATTENTION: This product has been safety tested and is only certified for use in a specific country. Refer to country designation located on outer carton.

These parts may be gas carrying or gas burning components. Please contact Weber-Stephen Products LLC Customer Service Department for genuine Weber-Stephen Products LLC replacement part(s) information.

⚠ WARNING: Do not attempt to make any repair to gas carrying, gas burning, igniter components or structural components without contacting Weber-Stephen Products LLC Customer Service Department. Your actions, if you fail to follow this Product Warning, may cause a fire, an explosion, or structural failure resulting in serious personal injury or death as well as damage to property.



WEBER-STEPHEN PRODUCTS LLC
www.weber.com®

© 2011 Designed and engineered by Weber-Stephen Products LLC
a Delaware limited liability company, located at 200 East Daniels Road, Palatine, Illinois 60067 U.S.A.
Printed in U.S.A.